



# Public Arts Commission Meeting

March 4, 2026 at 6 p.m.  
Fridley Civic Campus 7071 University Avenue NE

---

## Agenda

### Call to Order

### Roll Call

### Approval of Meeting Minutes

1. February 4, 2026 Public Arts Commission Minutes

### New Business

2. Art Trail Policy Document First Draft
3. Commons Park Sculpture Project Update
4. Springbrook Nature Center Art Bench Project
5. Utility Box Art Wrap Program Implementation

### Old Business

### Other Items

### Adjournment

---

#### Accessibility Notice:

- If you need free interpretation or translation assistance, please contact City staff.
- Si necesita ayuda de interpretación o traducción gratis, comuníquese con el personal de la ciudad.
- Yog tias koj xav tau kev pab txhais lus los sis txhais ntaub ntawv dawb, ces thov tiv tauj rau Lub Nroog cove neeg ua hauj lwm.
- Haddii aad u baahan tahay tarjumaad bilaash ah ama kaalmo tarjumaad, fadlan la xiriir shaqaalaha Magaalada.

Upon request, accommodation will be provided to allow individuals with disabilities to participate in any City of Fridley services, programs or activities. Hearing impaired persons who need an interpreter or other persons who require auxiliary aids should contact [CityClerk@FridleyMN.gov](mailto:CityClerk@FridleyMN.gov) or (763) 572-3450.

# AGENDA REPORT



---

**Meeting Date:** March 4, 2026  
**Meeting Type:** Public Arts Commission  
**Submitted By:** Mike Maher, Parks and Recreation Director  
Jesslyn Quiram, Engineering Technician  
**Title:** February 4, 2026 Public Arts Commission Minutes

---

## Background

---

Attached are the meeting minutes of the February 4, 2026 Public Arts Commission.

## Recommendation

---

Staff recommends approval of the February 4, 2026 Public Arts Commission Minutes.

## Attachments and Other Resources

---

1. PA\_ Commission Minutes- February 4 2026

### Vision Statement

We believe Fridley will be a safe, vibrant, friendly, and stable home for families and businesses.



# Public Arts Commission Meeting

February 4, 2026

6:00 PM

Fridley City Hall, 7071 University Ave. NE, Fridley, MN 55432

---

## Minutes

### **Call to Order**

Chair Collins called the Public Arts Commission meeting to order at 6:00 p.m.

### **Present**

Josh Collins, Chair  
Maija Sedzielarz, Vice Chair  
Ryan Fugleberg  
Gary Osterbauer  
Kara Ruwart  
Gary Swanson  
Frank Sedzielarz

Mike Maher, Parks and Recreation Director  
Jesslyn Quiram, Engineering Technician  
Councilmember Ann Bolcom

### **1. Approve Public Arts Commission Minutes for January 7, 2026**

Several corrections were noted in the minutes including a spelling error changing "hosing" to "hosting" on item 5 and to add the following update items to the workplan; Sacred Water, Shared Future, Springbrook Nature Center art project, programs and special events.

*Motion by Commissioner Swanson to approve, with corrections, the January 7, 2025 meeting minutes. Seconded by Commissioner Ruwart. The motion passed unanimously.*

### **New Business**

#### **2. Art Trail Concept Refinement**

Staff presented two concepts for an art trail in Fridley. One concept concentrated artwork into a walkable trail loop extending from the Fridley Civic Camps to Locke Park. The second concept focused on artwork installations in upcoming park projects with a wider geographic distribution of art installations across the City.

The Commission discussed that both concepts have merit and that opportunities to include art in new park projects should be explored. However, the group agreed that they should define a focus area so that more specific fundraising efforts can be undertaken and that the Civic Campus/Locke Park concept was the preferred area of focus.

*A motion was made by Commissioner Gary Swanson to:*

- *Focus the Commission's next project on a sculpture walk*
- *To define the area as being the Civic Campus and Locke Park*
- *To start with art on loan, but create a trail plan that can be expanded and include permanent art installations in addition to art on loan*
- *To request that staff develop a policy document to guide the program*
- *To set a goal for program implementation during the summer of 2027*

*Second by Commissioner Frank Sedzielarz. The motion passed unanimously.*

### 3. Draft Call for Art – Utility Box Wrap Program

Staff presented a draft of a call for art document to request submissions for a pilot program for artist-designed vinyl wraps for six utility boxes in Fridley. The Commission made the following suggestions:

- To add additional clarity around youth submissions and to make sure that it was clear if an applicant was submitting as an adult (18 years or older) or youth (Under 18 years of age).
- To have the program documents reviewed by the City Attorney
- To prohibit the use of designs created through artificial intelligence (AI)

*A motion was made by Commissioner Gary Swanson to approve the Call for Art pending completion of legal review and clarification of age requirements. Second by Gary Osterbauer. The motion passed unanimously.*

### **Old Business**

None

### **Other Items**

Commissioner Maija Sedzielarz shared details of an upcoming March 16<sup>th</sup> concert performance by the Fridley City Band and Fridley High School Band. An update was provided by staff on discussion with community partners to explore a public art project at Sylvan Hills Park as part of the Sacred Waters, Shared Future initiative taking place in 2026 to celebrate the Mississippi River.

## **Adjournment**

*Commissioner Gary Swanson made a motion to adjourn the meeting. A second was made by Commissioner Gary Osterbauer. The motion was passed unanimously.*

Respectfully submitted,

Mike Maher, Parks and Recreation Director  
Recording Secretary

# AGENDA REPORT



---

**Meeting Date:** March 4, 2026  
**Meeting Type:** Public Arts Commission  
**Submitted By:** Mike Maher, Parks and Recreation Director  
Jesslyn Quiram, Engineering Technician  
**Title:** Art Trail Policy Document First Draft

---

## Background

---

At the February 4, 2026 meeting of the Public Arts Commission, a motion was unanimously approved to proceed with further development of an art trail concept for the Fridley Civic Campus and Locke Park and for staff to begin drafting a policy document to guide the process. A first draft of a policy document, artist application and artwork submission application have been prepared for review and feedback by the Commission.

## Recommendation

---

## Attachments and Other Resources

---

1. Art Walk Program Policies and Guidelines 230223
2. Artist Application
3. Artwork Application

### Vision Statement

We believe Fridley will be a safe, vibrant, friendly, and stable home for families and businesses.



# Rotating Art Trail Pilot Program

Policies and Guidelines

DRAFT





# Rotating Art Trail Program

## Policies and Guidelines

---

### **Rotating Art Trail Program Policies and Guidelines:**

The City of Fridley Rotating Art Trail Program is a public art program designed to create a sense of place within the City and promote vibrancy, creativity, and community.

The City of Fridley has identified the area surrounding the Civic Campus and expanding into Locke Park as a centralized and walkable location for artists to showcase their talents and visitors to engage with the arts and outdoors. The pilot program implementation period will span from 2026-2027 and will allow staff, Commissions and Council to evaluate the selection process, program impact and maintenance responsibilities prior to program expansion.

This phased program implementation with future expansion opportunities will allow for art pieces to be rotated on an incremental schedule which will promote diversity and continual exploration and engagement as new pieces are mixed with existing installations.

### **Program Objectives:**

- Distinguish the City of Fridley as a community with a growing public art program.
- Provide access across the community to public art in a visible and easily traversed area.
- Determine the feasibility of an expanded rotating art program.
- Strengthen civic pride and engage residents in the arts.
- Enhance the lives of residents and visitors through exposure to visual arts.
- Provide a public venue for artists to showcase their talents and bring a sense of community and belonging by promoting community pride, civic engagement, and cultural history.

### **Application and Selection Guidelines:**

- Application is open to all artists or emerging artists that work in all media that can withstand outdoor public display.
- Submissions must include:
  - Completed Artist Information Form
  - Completed Artwork Information Form
  - Artwork Images:
    - For **Existing** work submit 2-3 high resolution digital images of existing artwork.
    - For **New** work that may not be constructed at the time of application submit 2-3 high resolution digital images of previous work and concept art for proposed design. All images to be labeled with title, date, and installation location.
  - Resume of work
- Artists must submit their application and design by the deadline date. No exceptions.



## Rotating Art Trail Program

### Policies and Guidelines

---

- Artists may submit more than one design. Up to three unique artwork submissions will be accepted for consideration.
- Selection scoring by the Public Arts Commission will include preference for Fridley residents.
- Final acceptance of the recommendations for selection by the Public Arts Commission are subject to final approval by the Fridley City Council.
- Selection will be based on artistic excellence, creativity and originality with further consideration towards visual impact, site appropriateness, and contribution to sense of place in Fridley.
- Designs that feature content unique to a particular culture should be designed with representation from the specified cultural group. For example, a design inspired by Hmong or Somali cultural tradition should be submitted by an artist who identifies as part of that cultural group or should include a narrative of how the artist collaborated with cultural stakeholders in the development of the design.

#### **Stipend and Incentives:**

- The City, in partnership with the Fridley Creative Arts Foundation, will provide a stipend of \$1,000 to selected artists or organizations.
- Program funding is provided by the non-profit Fridley Creative Arts Foundation.

#### **Location:**

- Artwork will be installed at various locations throughout the City of Fridley Civic Campus and the adjacent Lock Park. All sites will be in walkable areas that provide easy access to installed artwork. See exhibit X for details.

#### **Call for Art Process and Timeline:**

- Application Submission Deadline: TBD.
- Anticipated Selection of Artwork: TBD, meeting of Fridley Public Arts Commission.
- Final Design Notice to Artists: Prior to TBD.
- Artwork Installed: Summer 2027.
- Project timeline is subject to change.

#### **Displaying the Artwork via the City's Website:**

Representations of the selected artwork and/or photographs of the installed art pieces will be displayed on an interactive map of public art on the City of Fridley website and will include the location of the installation along with the name of the artist.



# Rotating Art Trail Program

## Policies and Guidelines

---

### **Artist Responsibilities:**

- It is the responsibility of the artist to submit a complete application by the due date listed on the application, as well as to include all required artwork in the specified format.
- The artist must provide a final original design meeting the specifications outlined in this document.
- The artist retains the copyright of the artwork; however, the City is provided with an irrevocable license for its non-commercial use.
- The artist must execute the City's Artist Agreement(s) with the City of Fridley.
- Insurance coverage is the responsibility of the artist/owner. Artist's insurance policy to include adequate coverage for damages, loss, or injury. Certificate of insurance to list the City of Fridley as additionally insured.
- The artist is responsible for transportation and installation of the artwork. The City of Fridley can assist with installation if arranged in advance.
- Artwork may be available for sale while on display, but shall not be removed until completing the full display term of this program.
- The artist is responsible for removal of the art piece at the end of the display term.
- The artist shall be responsible for all maintenance or repairs to the physical art piece while on display.

### **City Responsibilities:**

- The City will provide the base sizes and specifications including any installation requirements for each location.
- The City is responsible for the maintenance of the concrete pad and related components outside of the physical art piece.
- The City has the discretion to select or reject any artwork.

### **Design Criteria and Guidelines:**

- All artwork must be an original created by the artist.
- Artwork must not be created through the use of Artificial Intelligence (AI).
- Artwork must be durable enough to withstand the elements including extreme cold, temperature fluctuations, snow, rain, and direct sunlight.
- Artwork should be safe for public engagement, including children. Exhibited work is unattended and accessible to the public at all times.
- Artwork must not contain:
  - Political statements or specific persons
  - Discriminatory imagery or language
  - References, symbols, or numerology specific to any religion
  - Copyrighted or trademarked material



## Rotating Art Trail Program

### Policies and Guidelines

---

- Corporate or organizational branding (with the possible exception of Fridley-based non-profit organizations)
- Images of illegal activity
- References or imagery deemed offensive or controversial by the selection committee

### **Program Resources:**

Staff contacts for the Rotating Art Trail Program are:

**Mike Maher**

Parks and Recreation Director  
(763)572-3575

[Mike.Maher@FridleyMN.Gov](mailto:Mike.Maher@FridleyMN.Gov)

**Jesslyn Quiram**

Engineering Technician  
(763)572-3546

[Jesslyn.Quiram@FridleyMN.Gov](mailto:Jesslyn.Quiram@FridleyMN.Gov)

### Documents to create:

- Artist Information Form
- Artwork Information Form
- Map and Location information sheets – individual sheets with specific information for each installation location
- Rotational Art Artist Agreement

### Questions:

- Confirm stipend amount and frequency
- Confirm length of display term – do we want that noted?
- Will the City be responsible for installation?
- Are there specific amounts for insurance coverage that we would want?
- Do we want to require that Artists reside within a certain driving distance?
- Will the City take commission from sales and, if so, do we want to note that in the policy or only within the Artist Agreement?

# Rotating Art Trail Program Artist Information Form



## Artist Information:

Name \_\_\_\_\_

Address \_\_\_\_\_

Phone \_\_\_\_\_

Email \_\_\_\_\_

Website \_\_\_\_\_

## Artist Statement

All submissions must include:

- Artist Information Form
- Artwork Information Form
- Artwork Images
- Artist Resume of Work

# Rotating Art Trail Program Artwork Information Form



## Artwork Information:

Artist Name \_\_\_\_\_

Artwork Name \_\_\_\_\_

Artwork Description

Artwork Materials \_\_\_\_\_

Artwork Dimensions

Total Width \_\_\_\_\_ Total Length \_\_\_\_\_ Total Height \_\_\_\_\_

Base Width \_\_\_\_\_ Base Length \_\_\_\_\_

Installation Information

Base Materials \_\_\_\_\_

Mounting Method \_\_\_\_\_

Total Weight \_\_\_\_\_

Additional Installation Notes

All submissions must include:

- Artist Information Form
- Artwork Information Form
- Artwork Images
- Artist Resume of Work

# AGENDA REPORT



---

**Meeting Date:** March 4, 2026  
**Meeting Type:** Public Arts Commission  
**Submitted By:** Mike Maher, Parks and Recreation Director  
Jesslyn Quiram, Engineering Technician  
**Title:** Commons Park Sculpture Project Update

---

## Background

---

Artist Ken McCall has presented his detailed design drawings for his approved sculpture, Manoomin, to be installed at Commons Park. Staff are working as quickly as possible to review the design drawings and to facilitate the permitting process to meet the goal of installation prior to the park grand opening scheduled for Saturday, July 18, 2026. The concept design has been previously approved by both the Commission and Council, and the detailed design has no substantive change to warrant further design approval.

## Recommendation

---

## Attachments and Other Resources

---

1. MN Fridley-NG Drawing v8

### Vision Statement

We believe Fridley will be a safe, vibrant, friendly, and stable home for families and businesses.

# COMMONS PARK

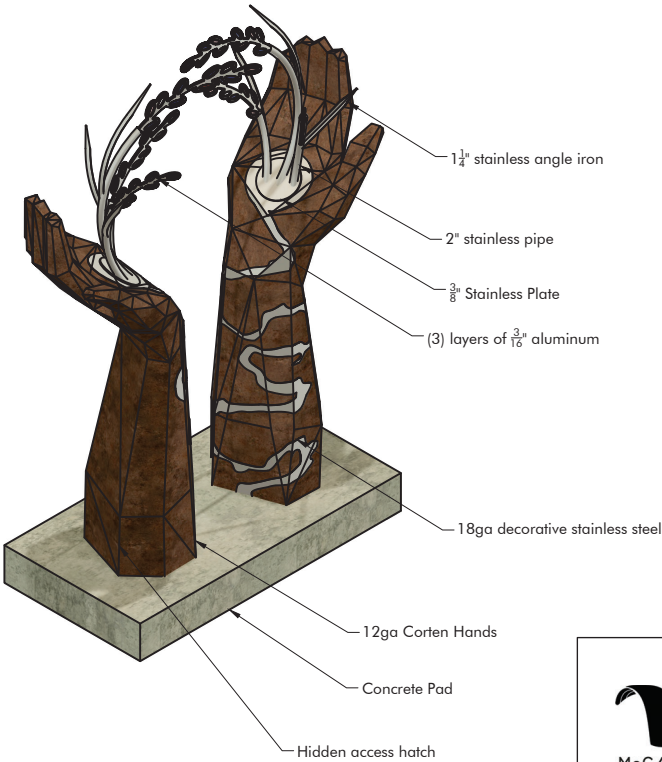

- Large sculptural corten hands, fabricated from 12ga steel.
- 18ga Stainless Steel rivers decorate the surface of the hands
- 2" schedule 40 Stainless Steel pipes adorn the palms of the hands, designed after the native rice of fridley.
- Rice pipes are attached to an internal pipe structure via a stainless plate
- Hands are bolted to concrete pad with concrete embedded anchors.
- Small access door on the back of arms grants access inside the hands.
- (2) #5 rebar meshes are inside of the concrete pad.
- Rice grass made from (3) layers of 3/16" aluminum
- Base plate is 1/2" thick

|  |              |            |        |           |
|--|--------------|------------|--------|-----------|
|  | PROJECT      |            |        |           |
|  | Ken McCall   |            |        |           |
|  | TITLE        |            |        |           |
|  | Commons Park |            |        |           |
| APPROVED   | SIZE         | CODE       | DWG NO | REV       |
| CHECKED  | B            |            |        |           |
| DRAWN  | 2/18/2026    | SCALE 1:25 | WEIGHT | SHEET 1/5 |

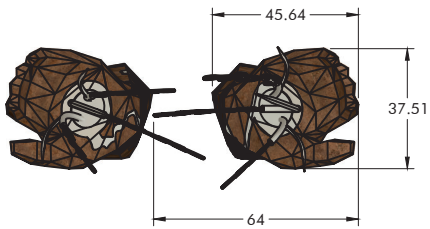
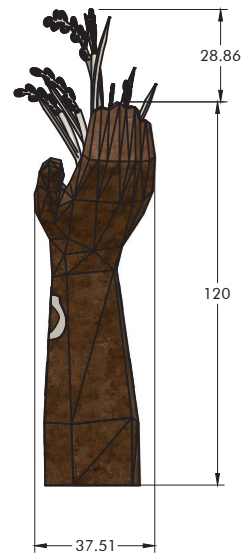
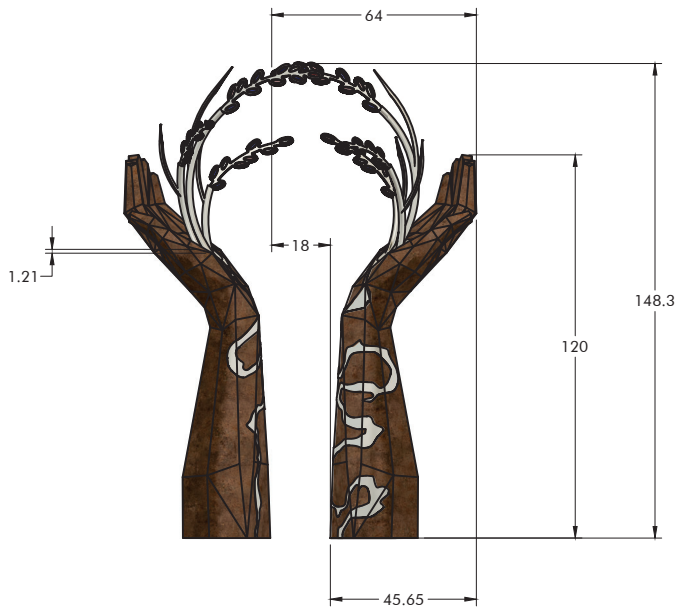

|   |           |            |        |           |              |
|---|-----------|------------|--------|-----------|--------------|
| <br><b>McCALL STUDIOS</b> |           | PROJECT    |        |           | Ken McCall   |
|   |           | TITLE      |        |           | Commons Park |
| APPROVED  | SIZE      | CODE       | DWG NO | REV       |              |
| CHECKED   | B         |            |        |           |              |
| DRAWN   | 2/18/2026 | SCALE 1:30 | WEIGHT | SHEET 2/5 |              |

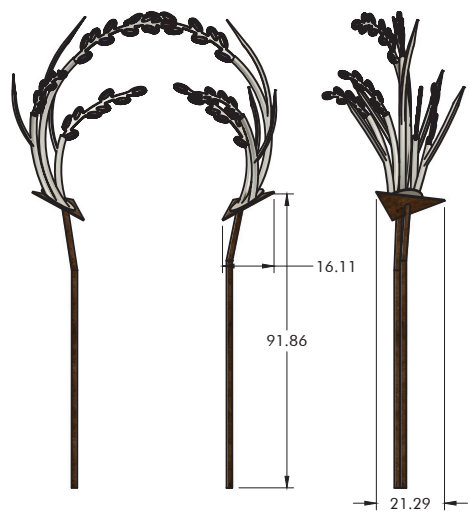
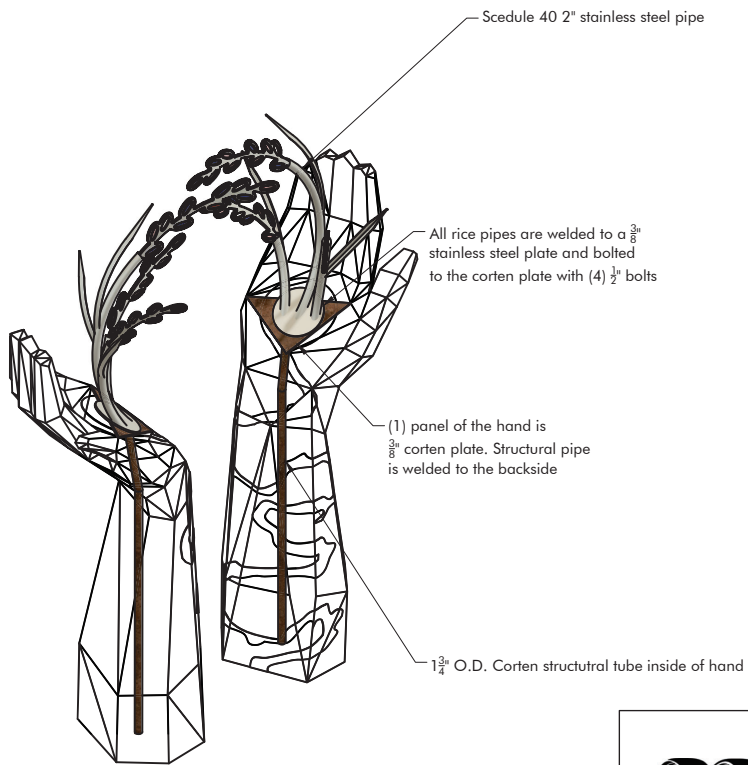

|  |           |              |        |           |  |
|--|-----------|--------------|--------|-----------|--|
|  |           | PROJECT      |        |           |  |
|  |           | Ken McCall   |        |           |  |
|  |           | TITLE        |        |           |  |
|  |           | Commons Park |        |           |  |
| APPROVED   | SIZE      | CODE         | DWG NO | REV       |  |
| CHECKED  | B         |              |        |           |  |
| DRAWN  | 2/18/2026 | SCALE 1:30   | WEIGHT | SHEET 3/5 |  |

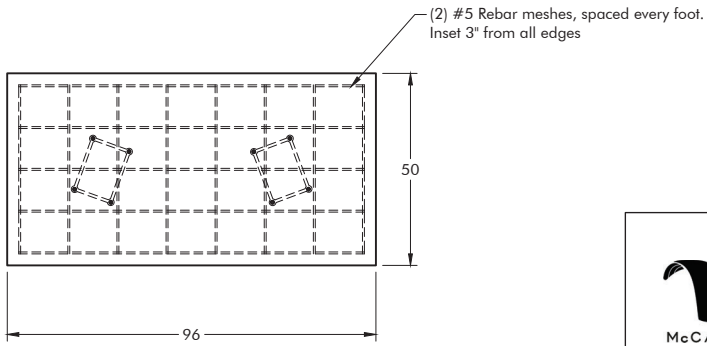
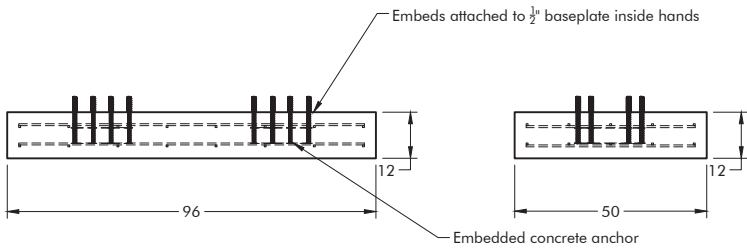

|   |                   |                          |        |           |
|---|-------------------|--------------------------|--------|-----------|
| <br><b>McCALL STUDIOS</b> | PROJECT           |                          |        |           |
|   | <b>Ken McCall</b> |                          |        |           |
|   |                   | TITLE                    |        |           |
|   |                   | <b>Commons Park</b>      |        |           |
| APPROVED  | SIZE              | CODE                     | DWG NO | REV       |
| CHECKED   | B                 |                          |        |           |
| DRAWN   | 2/18/2026         | SCALE 1/25 (from parent) | WEIGHT | SHEET 4/5 |

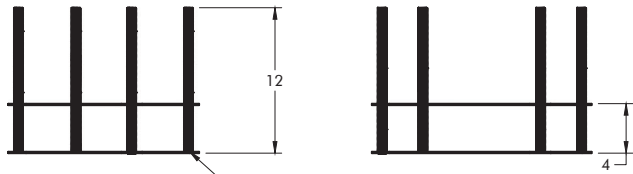

$\frac{3}{4}$ "-10 threaded rod



Embedded Anchor

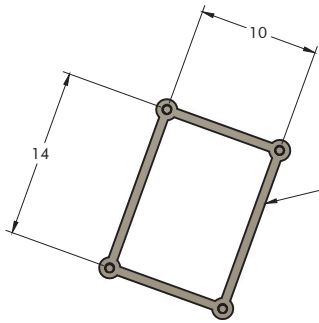

$\frac{1}{8}$ " steel connects the threaded rod

|  |             |              |           |        |  |
|--|-------------|--------------|-----------|--------|--|
|  |             | PROJECT      |           |        |  |
|  |             | Ken McCall   |           |        |  |
|  |             | TITLE        |           |        |  |
|  |             | Commons Park |           |        |  |
| APPROVED   | SIZE        | CODE         | DWG NO    | REV    |  |
| CHECKED  | B           |              |           |        |  |
| DRAWN  | simon lacey | 2/18/2026    | SCALE 1:8 | WEIGHT |  |
|  |             |              | SHEET 5/5 |        |  |

# AGENDA REPORT



---

**Meeting Date:** March 4, 2026  
**Meeting Type:** Public Arts Commission  
**Submitted By:** Mike Maher, Parks and Recreation Director  
Jesslyn Quiram, Engineering Technician  
**Title:** Springbrook Nature Center Art Bench Project

---

## Background

---

Springbrook Nature Center has been identified as a priority location for public art by the Fridley Public Arts Commission. Parks and Recreation Director Mike Maher attended the January meeting of the non-profit Springbrook Nature Center Foundation to provide an update on Fridley’s public art program. Nature Center staff and Foundation have expressed interest in further exploration of public art opportunities. A grant opportunity was identified through Xcel Energy to apply for funding for an interpretive art bench made from a recycled wind turbine blade. These benches come in unique shapes and can be purchased pre-primed to accept a mural or application of vinyl wrap. Staff have applied for grant funding which will likely cover most of the cost of the bench purchase. The Springbrook Nature Center Foundation has committed to support the project financially but has not made a commitment for a specific dollar amount. The group further suggested that the Fridley Creative Arts Foundation be contacted as a possible project partner. Staff will provide an overview of the product offerings from Noblewins and several quotes prepared for possible project implementation. Additional options for public art at the site are also under consideration.

## Recommendation

---

## Attachments and Other Resources

1. 2026 Noblewins Catalog
2. Noblewins Primed Product Guide
3. Fridley, MN - Primed Gateway
4. Fridley, MN - Gateway + Yosemite

## Vision Statement

We believe Fridley will be a safe, vibrant, friendly, and stable home for families and businesses.



**NOBLEWINS**  
**2026 CATALOG**



# TABLE OF CONTENTS

## The Noblewins Story 3

Crafted with Purpose  
Built to Last  
Designed to Inspire

## Materials 5

Primary Material  
Secondary Materials  
Finishes/Coatings

## Products 9

The Open Collection  
The Shaded Collection

## How to Buy 18

Cost Comparison  
Purchasing Information  
Frequently Asked Questions  
Contact Information



5



13



8



16



10



## OUR STORY

Noblewins was founded with the intent to reimagine--reimagine waste, reimagine spaces, and reimagine public seating. Our success has come from solving a common problem in an innovative way. With a history in renewable energy, our Leadership Team found the solution to transform thousands of discarded wind turbine blades into functional public art used across the country. What we do is more than just build benches, we bring dependability and durability to our public spaces. Most importantly, through the use of public art, Noblewins has given America's communities, parks, and schools the opportunity to share *their story*.

**CRAFTED  
WITH  
PURPOSE.**

**BUILT  
TO  
LAST.**

**DESIGNED  
TO  
INSPIRE.**



**We understand what matters to your community and the people who use our products.** Every component is carefully selected with purpose, ensuring each piece stands the test of time in both form and function.

**Simply put, we use the right materials to build public furniture.**

We set the bar for durability with a 25+ year lifecycle. It's no secret that people are tough on public amenities. **Our promise of no maintenance, is a game changer for communities, parks, and schools.** These pieces will transform and elevate any space in the community, serving as functional public art that is much more than seating—they are canvases for creativity, community expression, or telling a story.

# PRIMARY MATERIAL



## RETIRED WIND TURBINE BLADE

### MATERIAL BENEFITS

- Incredibly durable
- No maintenance
- No rust or corrosion
- Moisture resistant
- Extreme weather? No problem
- Visible way to “go green”



Wind turbine blades begin their commercial lifecycle in harsh environments producing energy. When they reach their end of life, they have historically been left in landfills as an unfortunate testament to fiberglass' durability. **These blades will not break down over time** and occupy thousands of acres in rural communities. **Noblewins has reimagined what a retired blade can become and the positive impact it can have in our communities.**

# SECONDARY MATERIALS



## UPCYCLED PVC LUMBER

A sustainable, low-maintenance finish that mimics natural wood. will not splinter, warp or fade.



## ALUMINUM FRAMES

Lightweight, rust-resistant, and built to provide lasting structural support in any environment.



## STAINLESS STEEL FASTENERS

316 grade Corrosion-resistant and built to withstand the harshest outdoor conditions.

Each product contains **97% recycled materials**, all while maintaining their visual appeal and the durability you expect for years to come.



# FINISHES & COATINGS

Each Noblewins piece is primed with Sherwin Williams Bond-Plex® primer to be painted by your local artists to bring vibrancy to your community or can be coated to blend into a space. Our solid color coatings are anti-graffiti and UV-resistant ensuring a clean look for the lifetime of the piece



## PRIMED

a blank white canvas that jumpstarts public art and invites community engagement



## SKYLINE STEEL | + \$249/piece

Stone gray, subtle and inviting. Sher-Loxane® 800 2-part epoxy with graffiti & UV resistance

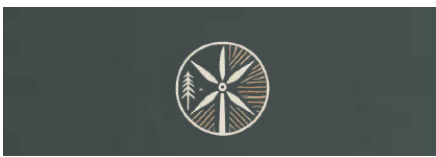

## NIGHT WATCH | + \$249/piece

Dark slate green and timeless. Sher-Loxane® 800 2-part epoxy with graffiti & UV resistance



## CUSTOM | + \$499/piece

1,700+ colors from the SW pallet. Sher-Loxane® 800 2-part epoxy with graffiti & UV resistance

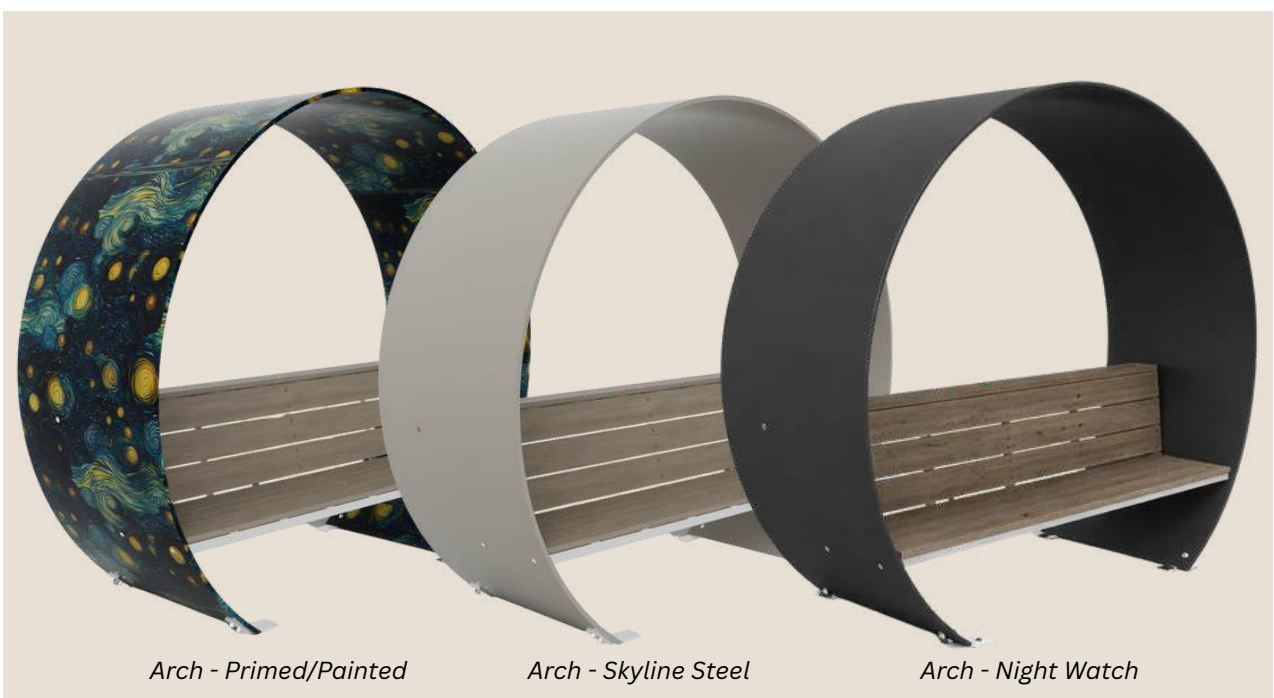

Arch - Primed/Painted

Arch - Skyline Steel

Arch - Night Watch

# FUNCTIONAL PUBLIC ART



**Turn Your Spaces Into Statements.  
Create Instant Attractions.**



# THE OPEN COLLECTION



**Uncomplicated. Durable. Always Ready.** The Open Collection is outdoor seating at its most reliable. No-frills, just solid, standout design. From the Zion Picnic Table to the Sequoia, Yosemite, and Big Bend benches, these pieces bring clean lines and unmatched durability to trails, campuses, and public spaces. Built to handle heavy use and harsh conditions, the Open Collection invites communities to gather, rest, and enjoy the outdoors without distraction.



Yosemite | \$3,775

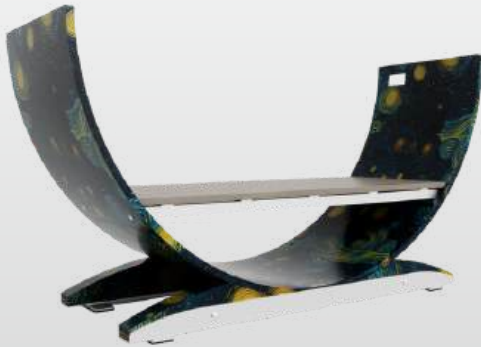

Big Bend | \$3,975



Sequoia | \$5,775

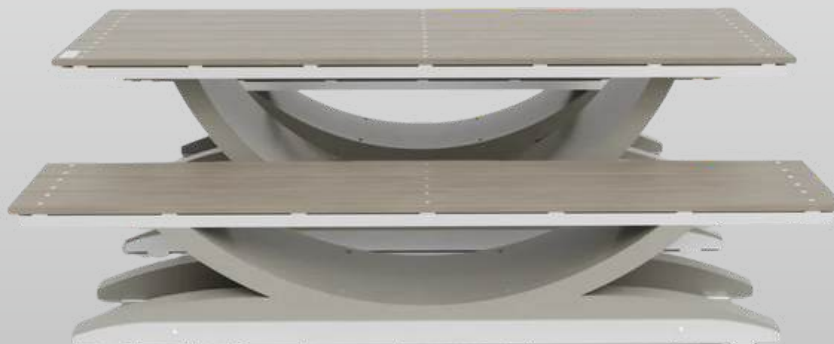

Zion | \$12,475



# YOSEMITE | \$3,775

Simple, solid, and built to last – the Yosemite bench fits right into park trails, public plazas, and outdoor spaces. Its low-profile design offers sturdy, reliable seating without dominating the landscape. Whether along pathways or in community areas, the Yosemite is tough, durable, and made to handle whatever the environment throws at it.

Dimensions:  
 Width: 60-72"  
 Depth: 24"  
 Height: 21"  
 Seat Height: 18"  
 Weight: 400 lbs



Accessories &  
 Add-Ons:  
 Plaque: \$84



+ \$249

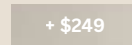

+ \$249

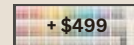

+ \$499



# BIG BEND | \$3,975

The Big Bend is a sculptural seating piece designed to elevate public spaces. Its smooth, continuous curve invites people to sit from any angle, encouraging interaction and gathering. Built for durability and visual impact, it serves as both functional furniture and public art—perfect for parks, campuses, and contemporary outdoor environments.

Dimensions:  
 Width: 60-72"  
 Depth: 24"  
 Height: 40"  
 Seat Height: 18"  
 Weight: 400 lbs



Accessories &  
 Add-Ons:  
 Plaque: \$84



+ \$249

+ \$249

+ \$499



# SEQUOIA | \$5,775

The Sequoia bench delivers bold design with unmatched comfort. Its curved frame and high-backed seat create a natural, supportive place to sit and relax. Perfect for parks, campuses, and public spaces, the Sequoia's solid, durable form makes it a standout piece while providing a cozy spot to unwind. Subtle details, like the exposed bolt holes, add character and a sense of craftsmanship that's hard to miss.

Dimensions:  
 Width: 72-84"  
 Depth: 30"  
 Height: 40"  
 Seat Height: 18"  
 Weight: 1200 lbs



Accessories &  
 Add-Ons:  
 Plaque: \$84



+ \$249

+ \$249

+ \$499



# ZIÖN | \$12,475

This isn't just a picnic table – it's *the* picnic table. At 8 feet long, seating 8 to 10 people comfortably, and wheel chair accessible on both ends, the Ziön dominates parks, campuses, and public spaces. Built tough to handle whatever comes its way, this table isn't just durable – it's practically indestructible. Whether for gatherings, lunch breaks, or community events, the Ziön is the best seat in the park.

Dimensions:  
 Width: 8'  
 Table Depth: 40"  
 Table Height: 32.5"  
 Seat Height: 18"  
 Weight: 1000 lbs



Accessories &  
 Add-Ons:  
 Plaque: \$84



+ \$249

+ \$249

+ \$499

# THE SHADED COLLECTION



**Bold Design. Instant Landmarks.** The Shaded Collection isn't just about seating – it's about making a statement. Featuring the Gateway, Everglade, and Arch, these pieces transform public spaces into unforgettable destinations. With their iconic curved frames and built-in shade, they naturally draw people in – creating the perfect blend of form, function, and architectural flair. Ideal for parks, campuses, and gathering spaces that need a focal point or picture-perfect spot.



Gateway | \$9,775



Everglade | \$8,475

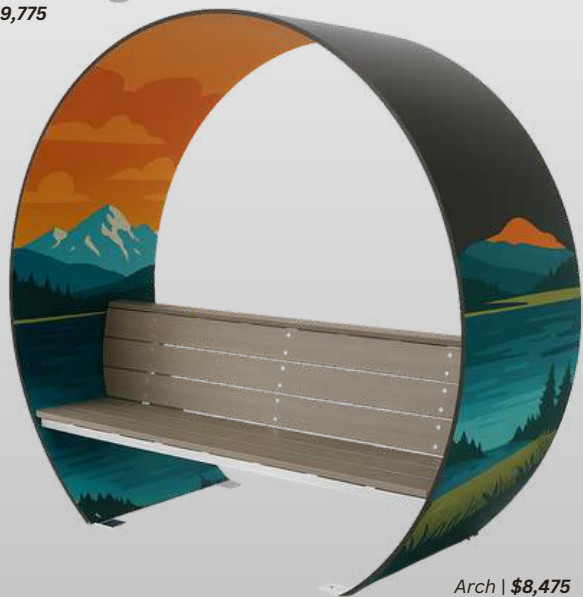

Arch | \$8,475



# GATEWAY | \$9,475

The Gateway Bench elevates any outdoor setting with its striking circular frame and minimalist profile. More than a simple seat, it becomes an iconic landmark that naturally draws people in. This bench is picture perfect—framing views and turning anywhere into a memorable destination. It's a bold fusion of durability and design that transforms landscapes into experiences.

Dimensions:  
 Width: 90-96"  
 Depth: 36"  
 Height: 80-86"  
 Seat Width: 72-78"  
 Weight: 2000 lbs



Accessories &  
 Add-Ons:  
 Plaque: \$84



+ \$249

+ \$249

+ \$499



# EVERGLADE | \$8,475

More than just a swing – the Everglade is a statement piece that transforms any space into a destination. Its bold, curved frame draws attention, inviting people to stop, sit, and enjoy the moment. Perfect for parks, campuses, and city spaces, the Everglade creates an eye-catching focal point that encourages gathering, photos, and relaxation. Built to last, it stands strong against weather and wear, making it as functional as it is striking.

Dimensions:  
 Width: 90-96"  
 Depth: 36"  
 Height: 80-86"  
 Seat width: 48"  
 Weight: 2000 lbs



Accessories & Add-Ons:  
 Plaque: \$84



+ \$249

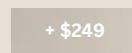

+ \$499



# ARCH | \$8,475

The Arch bench makes a bold statement with its sleek, curved design and covered frame. More than just a place to sit, it transforms parks, campuses, and public spaces into gathering spots that stand out. Its architectural form offers shade, shelter, and style, creating a natural focal point that people gravitate toward. Built to endure heavy use and harsh weather, the Arch Bench blends durability with eye-catching design.

Dimensions:  
 Width: 90-96"  
 Depth: 36"  
 Height: 80-86"  
 Seat Width: 72-78"  
 Weight: 2000 lbs



Accessories &  
 Add-Ons:  
 Plaque: \$84



+ \$249

+ \$249

+ \$499

# PURCHASING INFO

Sole source supplier

Made to order

Lead time: 3-6 months

Limited production slots available

Noblewins is proud to craft all of our products in the USA.



# COST COMPARISON

What Will Your Bench Cost Over 25 Years?



|                           |                |                  |                 |                  |                  |
|---------------------------|----------------|------------------|-----------------|------------------|------------------|
| Average Cost              | <b>\$5,775</b> | \$5,000          | \$3,000         | \$2,500          | \$1,000          |
| Maintenance Cost          | <b>\$0</b>     | \$150/year       | \$250/year      | \$320/year       | \$520/year       |
| 25-Year Replacement Cycle | <b>None</b>    | 1.5x             | 2x              | 2-3x             | 3x               |
| Total 25-Year Cost        | <b>\$5,775</b> | <b>\$16,250</b>  | <b>\$15,250</b> | <b>\$18,000</b>  | <b>\$17,000</b>  |
| Additional Budgeting      | <b>None</b>    | <b>-\$10,475</b> | <b>-\$9,475</b> | <b>-\$12,225</b> | <b>-\$11,225</b> |

## WHY CHOOSE NOBLEWINS

- Lowest Total Cost – No maintenance or replacements needed over 25 years
- No Assembly Required – Delivered fully built and ready to install
- Durability That Lasts – Built to withstand the elements and heavy use
- Outperforms Traditional Options – Replaces 2-3 wood, metal, or concrete benches
- Public Art Ready – Custom-painted options turn seating into lasting community art
- Sustainable Choice – Made from upcycled wind turbine blades

**2026 CATALOG**

**CRAFTED WITH PURPOSE.  
BUILT TO LAST.  
DESIGNED TO INSPIRE.**



**NOBLEWINS**

**READY TO BRING YOUR VISION TO LIFE?**

**WWW.NOBLEWINS.COM**

**(440) 306-9006**

**INFO@NOBLEWINS.COM**

**15000 MADISON AVENUE, LAKEWOOD, OH**

## Transforming Your Noblewins Piece into a Custom Work of Art

Every Noblewins product is designed to serve as a high-quality, durable foundation for your community's creativity. This packet provides essential information to help you collaborate with local artists or groups. Whether you choose to apply a hand-painted mural or a professional vinyl wrap, these standards ensure your custom design remains vibrant and protected for years to come.

### Surface Prep (Painting or Vinyl Wrapping)

To ensure the best results, please follow these guidelines:

- The PRIMED surface must remain clean and dry. Paint within 30 days of delivery for optimal adhesion and mural longevity. If the product is stored indoors and protected from moisture and sunlight, the PRIMED surface will be preserved for a longer period of time.
- If your product arrives wrapped, remove any wrapping immediately upon delivery. Leaving it wrapped can trap moisture and damage the primer.
- If applying paint or vinyl wrap after 60 days, or the PRIMED surface no longer appears clean, we recommend a light sanding or cleaning to remove any dust or surface breakdown before applying paint or vinyl wrap.

#### Applying an Artist's Mural



##### Step 1: Prep the Surface

- Wipe clean with a damp cloth
- If dusty or slick, lightly scuff with 220-grit sandpaper and wipe again
- Ensure the surface is dry before painting

##### Step 2: Recommended Paints

- Sherwin-Williams Resilience, SuperPaint, or Duration Exterior Acrylic
- Nova Color Acrylic Artist Paints
- Behr Ultra or Marquee Exterior Acrylic Latex

##### Step 3: Optional Clear Coat for Protection

- Sher-Clear 1K (Sherwin-Williams)
- World's Best Graffiti Coating
- Golden MSA Varnish (Gloss or Satin) wit UVLS
  - Apply 1-2 coats once mural is fully dry (24-48 hrs)
  - Always test a small area first for compatibility

#### Applying Vinyl Wrapping



##### Recommended Vinyl Materials

- Avery Dennison MPI 1105 SuperCast (10 year)
- 3M Controltac Graphic Film IJ180 (5 year)
- Orajet 3951RA + Oraguard 290 laminate (5 year)

##### Application Tips

- Clean surface thoroughly
- Apply between 60°F - 80°F
- Use heat guns and rubber tools to remove air pockets
- Laminate for UV/graffiti protection

# YOSEMITE

---



**Width:** 62-66"

**Depth:** 24"

**Height:** 20"

**Paintable Surface Area:** 33.5ft<sup>2</sup>

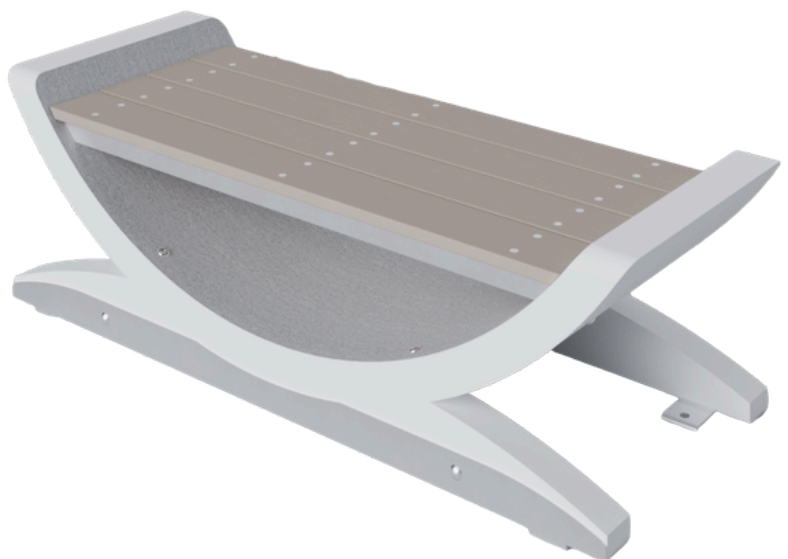

# BIG BEND

---



**Width:** 72-76"

**Depth:** 24"

**Height:** 40"

**Paintable Surface Area:** 48ft<sup>2</sup>

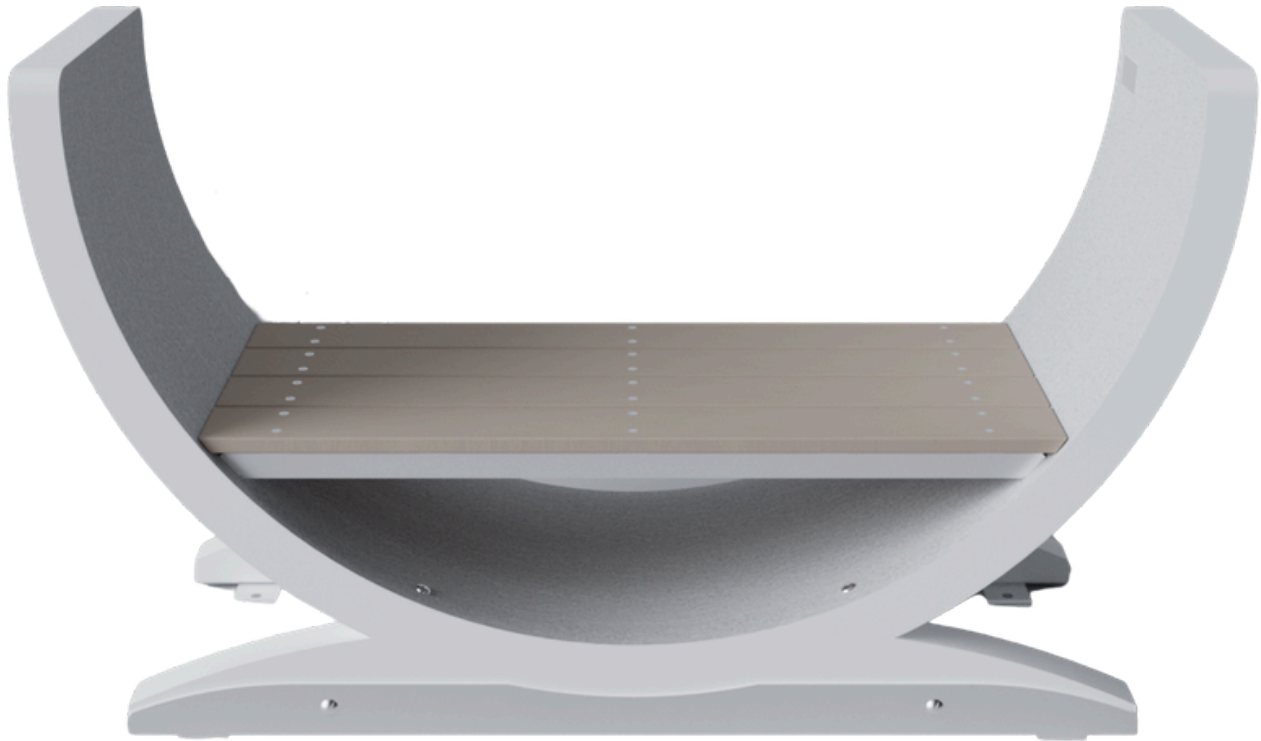

# CUYAHOGA

---



**Width:** 96"

**Depth:** 17"

**Height:** 18"

**Paintable Surface Area:** 23.5ft<sup>2</sup>

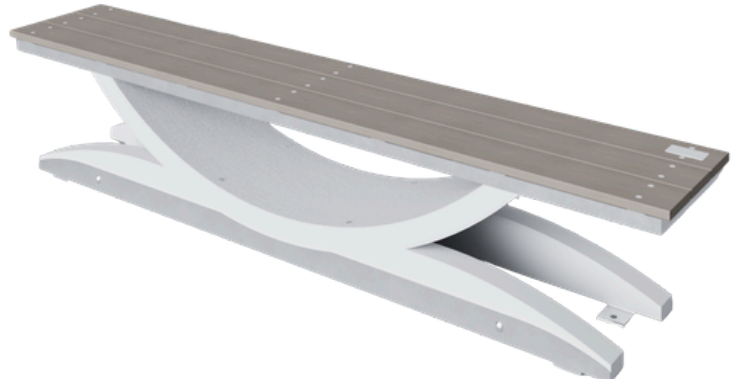

# SEQUOIA

---



**Width:** 78"

**Depth:** 30"

**Height:** 40"

**Paintable Surface Area:** 60ft<sup>2</sup>

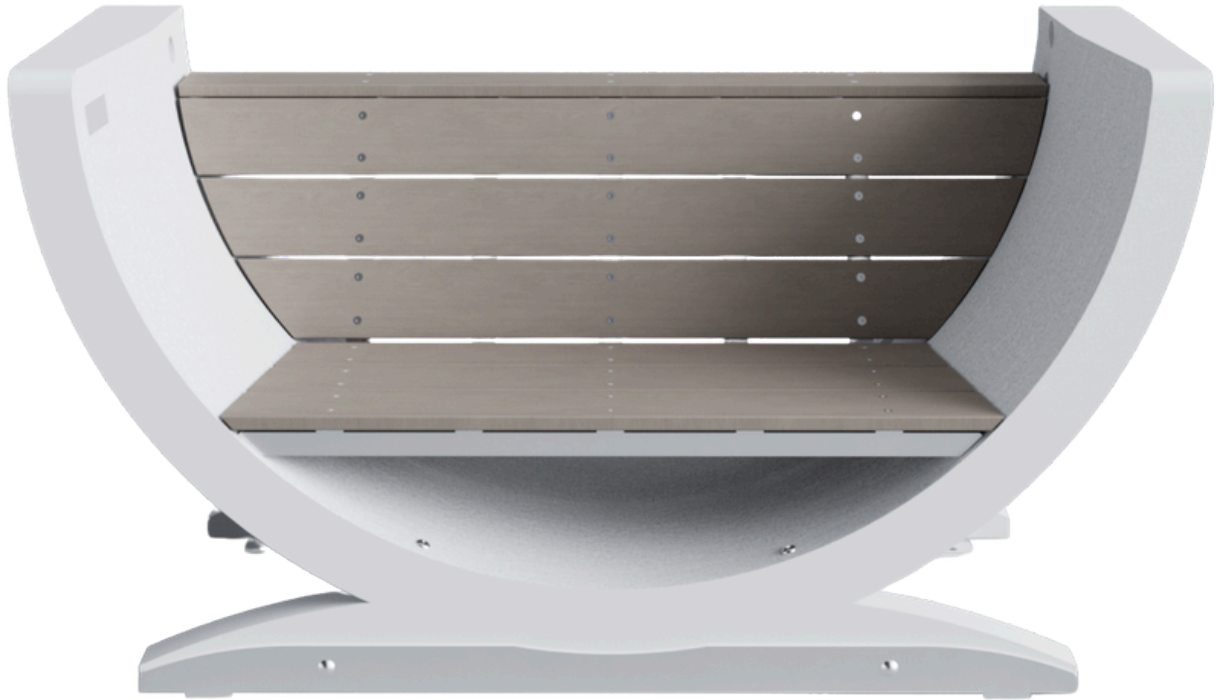

# EVERGLADE

---



**Width:** 96"

**Depth:** 36"

**Height:** 86"

**Paintable Surface Area:** 124ft<sup>2</sup>



# ARCH

---

**Width:** 96"

**Depth:** 36"

**Height:** 87"

**Paintable Surface Area:** 123.5ft<sup>2</sup>



# GATEWAY

---



**Width:** 96"

**Depth:** 36"

**Height:** 87"

**Paintable Surface Area:** 123.5ft<sup>2</sup>



# GLACIER

---



**Width:** 96"

**Depth:** 48"

**Height:** 30"

**Paintable Surface Area:** 37.25ft<sup>2</sup>



# VINYL WRAP

EVERGLADE

**NOBLEWINS**  
THE BENCHMARK FOR PUBLIC ART

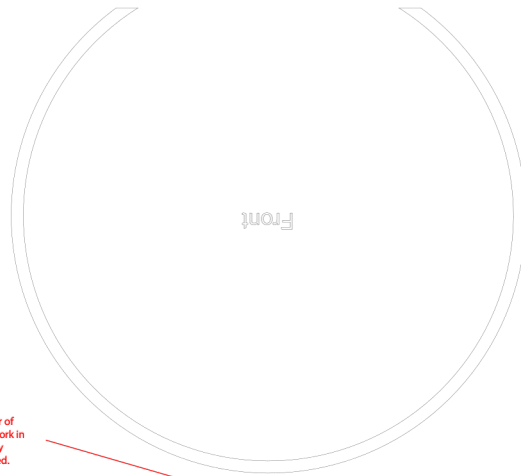

**HARDWARE MOUNTING POINTS**  
These areas indicate physical bench attachments. Keep these zones clear of essential design elements. Any artwork in these regions will be partially or fully obscured by the bench once installed.

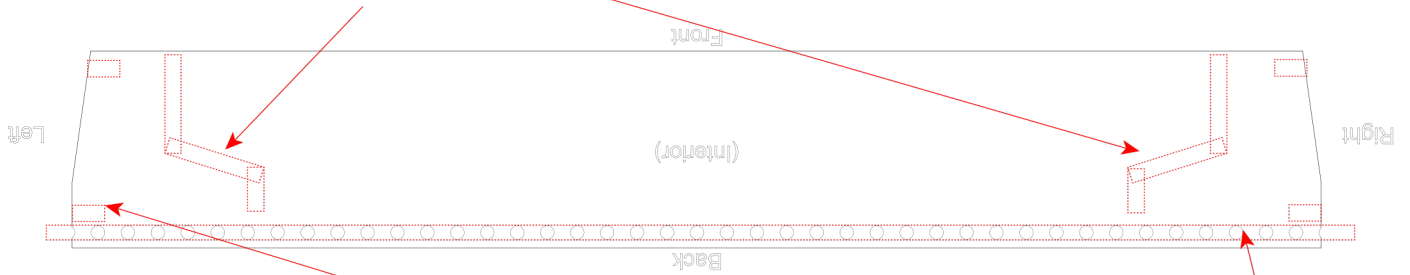

**ANCHOR / FOOT / CUTOUTS (RESERVED)** Red boxes indicate where bench anchoring feet will be positioned. Vinyl will be removed at these locations. Maintain a 0.25" design buffer around these zones to ensure no critical artwork is lost during the cutout process.

**ATTENTION: MANUAL CUT ZONE**  
Perforations will be hand-cut on-site. Do not place essential design elements near these holes. A bleed is required, but treat the outlined perimeter (red dashes) as a high-variance area.

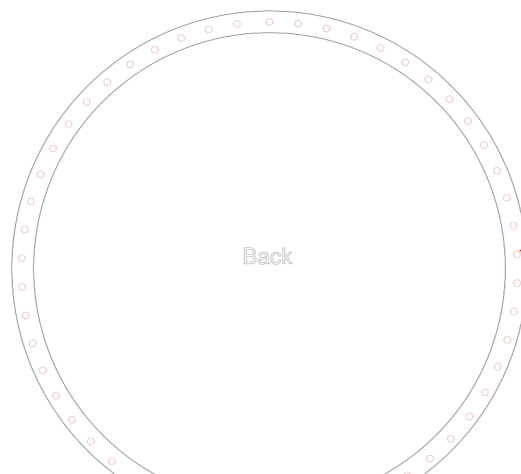
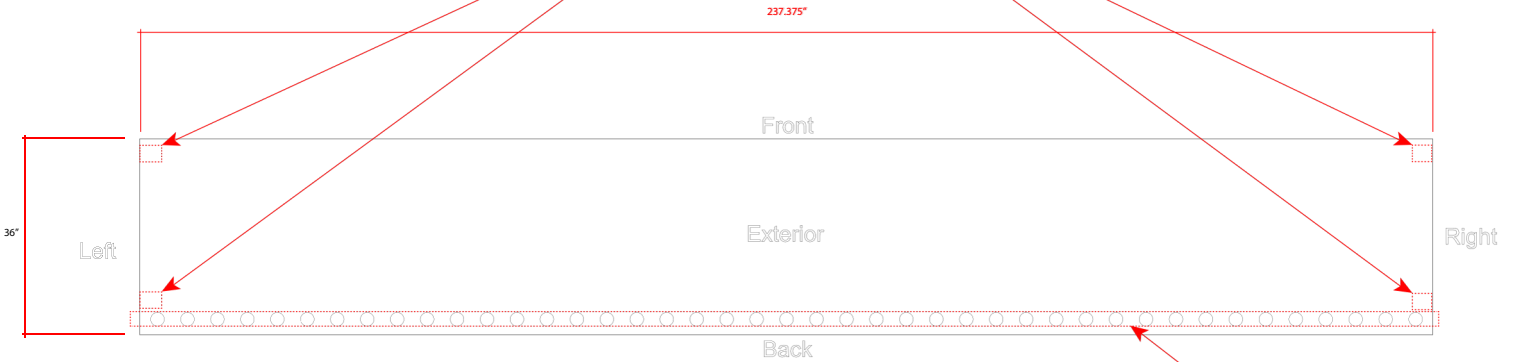

**ATTENTION: MANUAL CUT ZONE**  
Perforations will be hand-cut on-site. Do not place essential design elements near these holes. A bleed is required, but treat the outlined perimeter (red dashes) as a high-variance area.

# VINYL WRAP

## ARCH

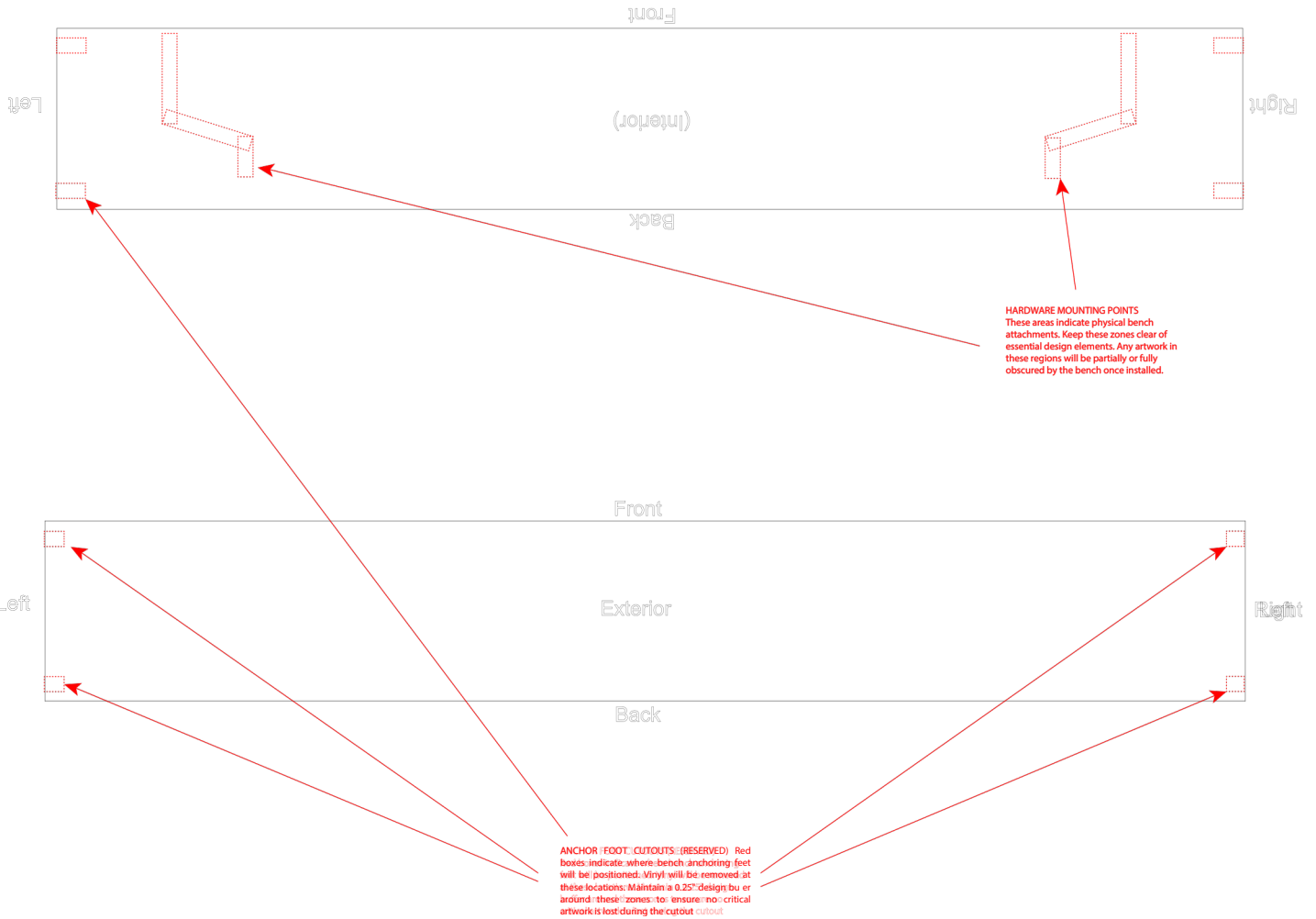

# VINYL WRAP

## GATEWAY

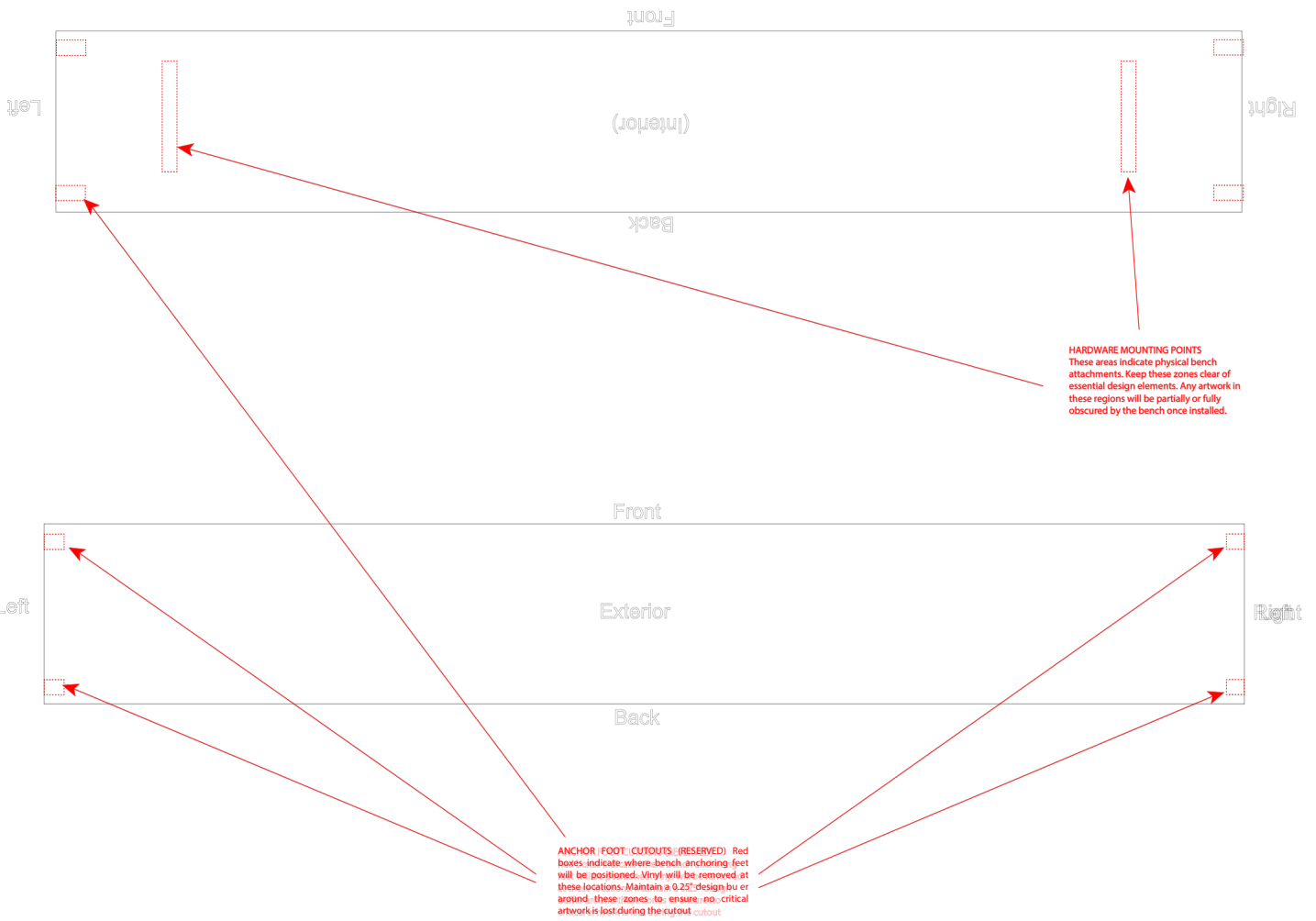



**Fridley, MN**  
MN

**Tara Rogness**  
tara.rogness@fridleymn.gov

**Mike Maher**  
mike.maher@fridleymn.gov  
763-572-3575

Reference: 20260216-122327887  
Quote created: February 16, 2026  
Quote expires: March 18, 2026  
Quote created by: Ben McGuire

bmcguire@noblewins.com  
+14403067325

**Comments from Ben**

Final freight to be calculated at time of order

**Products & Services**

| Image   | Item & Description   | Quantity | Unit Price | Total      |
|---|--|----------|------------|------------|
|  | <p>Gateway</p> <p>Bench comes primed and prepared for community artists to create their own custom mural design on-site.</p> | 1        | \$9,475.00 | \$9,475.00 |

|                   |                    |
|-------------------|--------------------|
| One-time subtotal | \$9,475.00         |
| <hr/>             |                    |
| Estimated Freight | \$2,160.00         |
| <hr/>             |                    |
| <b>Total</b>      | <b>\$11,635.00</b> |

By signing this quote, you agree to Noblewins' [Terms & Conditions](#).

### Signature

Before you sign this quote, an email must be sent to you to verify your identity. Find your profile below to request a verification email.

|   |                            |
|---|----------------------------|
| <p><b>Mike Maher</b><br/>mike.maher@fridleymn.gov</p> | <p>[ sig req signer1 ]</p> |
|---|----------------------------|

### Questions? Contact me



Ben McGuire  
bmcguire@noblewins.com  
+14403067325

Noblewins  
15000 Madison Avenue  
Floor 2  
Lakewood OH 44107  
United States



**Fridley, MN**  
MN

**Tara Rogness**  
tara.rogness@fridleymn.gov

**Mike Maher**  
mike.maher@fridleymn.gov  
763-572-3575

Reference: 20260216-122725997  
Quote created: February 16, 2026  
Quote expires: March 18, 2026  
Quote created by: Ben McGuire

bmcguire@noblewins.com  
+14403067325

**Comments from Ben**

Final freight to be calculated at time of order

**Products & Services**

| Image   | Item & Description  | Quantity | Unit Price | Total      |
|---|---|----------|------------|------------|
|  | Gateway<br>Bench comes primed and prepared for community artists to create their own custom mural design on-site. | 1        | \$9,475.00 | \$9,475.00 |

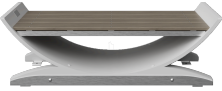
| Image   | Item & Description  | Quantity | Unit Price | Total      |
|---|---|----------|------------|------------|
|  | <p>Yosemite</p> <p>Bench comes primed and prepared for community artists to create their own custom mural design on-site.</p> | 2        | \$3,775.00 | \$7,550.00 |

One-time subtotal \$17,025.00

Estimated Freight \$2,160.00

**Total \$19,185.00**

By signing this quote, you agree to Noblewins' [Terms & Conditions](#).

### Signature

Before you sign this quote, an email must be sent to you to verify your identity. Find your profile below to request a verification email.

|   |                            |
|---|----------------------------|
| <p><b>Mike Maher</b><br/>mike.maher@fridleymn.gov</p> | <p>[ sig req signer1 ]</p> |
|---|----------------------------|

### Questions? Contact me



Ben McGuire  
bmcguire@noblewins.com  
+14403067325

Noblewins  
15000 Madison Avenue  
Floor 2  
Lakewood OH 44107  
United States

# AGENDA REPORT



---

**Meeting Date:** March 4, 2026  
**Meeting Type:** Public Arts Commission  
**Submitted By:** Mike Maher, Parks and Recreation Director  
Jesslyn Quiram, Engineering Technician  
**Title:** Utility Box Art Wrap Program Implementation

---

## Background

---

A call for art announcement was presented to the Public Arts Commission on February 4, 2026. The Commission recommended updates to the document to include review by the City Attorney, to prohibit art created through artificial intelligence (AI), and to further clarify whether a submission was to be categorized as a standard adult artist submission or youth artist submission. Updates were made based on the legal review and Commission input and staff are working to post the information on the City website to begin the call for art. Staff will provide an update to the Commission on the status of the program and facilitate a discussion on utilizing the contacts and networks of the Commission to promote and raise awareness of the call for art.

## Recommendation

---

## Attachments and Other Resources

1. Call for Art Utility Box Wrap Pilot Program
2. Utility Box Art Wrap Program Policies and Guidelines 11-25 (2)
3. Utility Box Wrap - Artist Application - FORM

## Vision Statement

We believe Fridley will be a safe, vibrant, friendly, and stable home for families and businesses.



# Call for Art

Utility Box Art Wrap Pilot Program  
Revised 2/26/2026





## Call for Art

Utility  
Box Wrap Pilot Program

---

### Call to Artists

The City of Fridley is seeking original artwork from area artists to replicate on vinyl wraps that will be installed on utility boxes along University Avenue in Fridley. This is a limited-scope pilot program in partnership with the Minnesota Department of Transportation and the Fridley Creative Arts Foundation. The Utility Box Art Wrap program is part of the City of Fridley's public art program, launched in 2024 to add character, vibrancy and sense of place to our community.

**Eligibility:** This opportunity is open to artists residing in or having a strong relationship with the City of Fridley. Examples may include working or attending school in Fridley or being affiliated with a Fridley-based non-profit organization. Preference will be given to current residents of the City of Fridley.

A variety of mediums will be considered if the artwork can be successfully converted to a digital file format. All non-youth submissions must be in the specified digital format detailed below. Artwork must be original to the artist and not created using Artificial Intelligence (AI).

Artists will receive \$500 for each artwork submission selected by the Fridley Public Arts Commission for use in the program. Final selection and disbursement of the \$500 award is contingent on the individual signing an artwork use agreement with the Minnesota Department of Transportation.

**Call Open:** February 27 – April 22, 2026

### Submission Materials:

- Artwork images
  - Artists may submit multiple images for consideration in digital format (.jpg, .pdf, .ai, .eps)
  - Youth artists age 17 or younger may submit artwork in alternative formats for consideration but selection may be contingent on discretion by the selection committee on the feasibility of conversion of artwork to digital format. For example, flat artwork on paper may be scanned and converted to digital format where three-dimensional artwork cannot be converted.
- Completed Artist Application
  - Include artist name, address, phone and email.
  - Include a narrative of 100 words or less describing the artist's connection to the City of Fridley (resident, non-profit affiliation, work, etc.)
  - Description of the artwork including title. If artwork contains elements specific to a specific ethnic or cultural group, include narrative of artist's background or collaboration demonstrating cultural representation.



## Call for Art

### Utility Box Wrap Pilot Program

---

- Email your submission to both: [Mike.Maher@FridleyMN.gov](mailto:Mike.Maher@FridleyMN.gov) and [Jesslyn.Quiram@FridleyMN.gov](mailto:Jesslyn.Quiram@FridleyMN.gov). Non-digital submissions must be delivered in person or by mail along with all requested information to: City of Fridley, 7071 University Avenue NE, Fridley, MN 55432.

**Selection Process:** Selections will be made by the Fridley Public Arts Commission and recommended to the Fridley City Council for final approval. Up to six submissions will be selected in total. Evaluation of submissions will be based on:

- Quality of artwork
- Originality and creativity of artwork
- Artwork contributing to sense of place in Fridley
- Applicability to the process of vinyl printing and application to the utility boxes selected for the pilot program
- Strength of narrative describing the artist's connection to the City of Fridley
- Youth submissions may receive preference if all criteria are met
- Artists will be notified of their selection prior to May 29, 2026

**Additional Information:** See full program criteria, template, and policy at [\[insert link to Public Arts Page/PDF of Policy Document\]](#)

**Questions:** Please contact:

Mike Maher, Parks and Recreation Director

City of Fridley

[Mike.Maher@FridleyMN.gov](mailto:Mike.Maher@FridleyMN.gov)

(763)572-3575

Jesslyn Quiram, Engineering Technician

City of Fridley

[Jesslyn.Quiram@FridleyMN.gov](mailto:Jesslyn.Quiram@FridleyMN.gov)

(763)572-3546



# Utility Box Art Wrap Pilot Program

Policies and Guidelines

Revised 2/26/2026





# Utility Box Art Wrap Program

## Policies and Guidelines

---

### **Utility Box Art Wrap Pilot Program Policies and Guidelines:**

The City of Fridley Utility Box Art Program is a public art program designed to transform utility boxes in the City into distinctive works of art, creating a more welcoming, vibrant, and attractive landscape. The City is seeking original designs by artists to wrap up to six designated utility boxes in Fridley.

The City of Fridley has identified six utility boxes along University Ave. (HWY 47) that will serve as a pilot program for utility box wraps to assist in evaluation of an expanded program. The pilot program implementation period will span from 2025-2027 and will allow staff, Commissions and Council to evaluate the selection process, program impact and maintenance responsibilities prior to possible program expansion.

### **Program Objectives:**

- Distinguish the City of Fridley as a community with a growing public art program.
- Provide access across the community to public art in a high-traffic area.
- Determine the feasibility of an expanded utility box art wrap program.
- Strengthen civic pride and engage residents in the arts.
- Enhance the lives of residents and visitors through exposure to the arts.
- Provide a public venue for artists and aspiring artists to showcase their talents and bring a sense of community and belonging by promoting community pride, civic engagement, and cultural history.

### **Application and Selection Guidelines:**

- The Public Arts Commission will score submissions using established evaluation criteria.
- Individuals of all ages may apply but minors must have a legal guardian submit the application on their behalf.
- Fridley-based non-profit organizations may apply. Non-profit branding, if approved, may only be incorporated if it is secondary to the artistic design and is not promotional in nature.
- Submissions must be in the specified digital format and resolution. Minors who wish to submit artwork but are unable to convert the artwork to the specified format may apply, however the selection committee may choose not to select submissions of this nature if the cost to the City is prohibitive to convert submissions to the appropriate format.
- Artists must submit their application and design by the deadline date. No exceptions.
- Artists may submit more than one design for consideration.
- Selection scoring by the Public Arts Commission will include preference for Fridley residents and may include preference for youth submissions.



## Utility Box Art Wrap Program

### Policies and Guidelines

---

- Final acceptance of the recommendations for selection by the Public Arts Commission are subject to final approval by the Fridley City Council.
- Selection will be based on artistic excellence, creativity and originality with further consideration towards visual impact and contribution to sense of place in Fridley.
- Designs that feature content unique to a particular culture should be designed with representation from the specified cultural group. For example, a design inspired by Hmong or Somali cultural tradition should be submitted by an artist who identifies as part of that cultural group or should include a narrative of how the artist collaborated with cultural stakeholders in the development of the design.

#### **Stipend and Incentives:**

- City, in partnership with the Fridley Creative Arts Foundation, will provide a stipend of \$500 to selected artists or organizations.
- Program funding is provided by the non-profit Fridley Creative Arts Foundation.

#### **Call for Art Process and Timeline:**

- Application Submission Deadline: Thursday, April 22, 2026.
- Anticipated Selection of Artwork: May 6, 2026, meeting of Fridley Public Arts Commission.
- Final Design Notice to Artists: Prior to May 29, 2026.
- Artwork Installed: Summer 2026.
- Project timeline is subject to change.

#### **Displaying the Artwork via the City's Website:**

Representations of the selected artwork and/or photographs of the installed art wraps will be displayed on an interactive map of public art on the City of Fridley website and will include the location of the installation along with the name of the artist.

#### **Artist Responsibilities:**

- Submission of artwork implies artist's agreement to terms and conditions of the Fridley Utility Box Art Wrap Program.
- It is the responsibility of the artist to submit a complete application by the due date listed on the application, as well as to include all required artwork in the specified format.
- The artist must provide a final original design meeting the specifications pertaining to dimension, layout, resolution and content. The artwork may include an artist



## Utility Box Art Wrap Program

### Policies and Guidelines

---

signature on one face of the design and may not be larger than 36 square inches on the final printed product.

- Artwork must be original to the artist and not created through the use of Artificial Intelligence (AI). Artificial intelligence shall be defined as any computer-generated content created through the use of generative machine learning systems that autonomously produce images, artwork, or design elements based on text prompts, image prompts, or other inputs, with minimal or no direct human rendering of the final visual output. All submissions imply a certificate of non-AI use.
- The artist shall transfer all rights, including ownership and copyright to the Minnesota Department of Transportation; however, the artist and City are provided with an irrevocable license for its non-commercial use and may reproduce the image or likenesses of the image for non-commercial purposes.
- The artist must execute all artist agreements with the City of Fridley and Minnesota Department of Transportation including a Waiver of Moral Rights Pursuant to Visual Artistic Rights Act (VARA).

#### **Youth Submissions**

- Youth submissions needing additional formatting must be clearly labeled as such.
- Youth art must be submitted by a legal guardian on behalf of the youth artist.
- Selected youth artists will have their \$500 stipend paid to their legal guardian.
- Youth art must comply with all the requirements of non-youth art, unless otherwise specified.
- The Public Arts Commission may limit the number of youth submissions selected if digital conversion or artwork is required.

#### **City Responsibilities:**

- Provide the template of the utility box layout for original artwork with specifications on accepted file types and resolution.
- The City will install the selected designs as a vinyl wrap and make the determination on which designs will be assigned to specific utility box locations.
- The City is responsible for the maintenance of artwork and expects a lifespan of 8-10 years for the applied vinyl wraps.
- The City has the right to copy, reproduce and adjust the artwork as it sees fit, in perpetuity.
- The City has the right to transfer ownership of the vinyl wrap and non-commercial rights for artwork to the Minnesota Department of Transportation if necessary to comply with requirement of the right of way for University Ave. (Hwy. 47)
- The City has the right to remove, replace or adjust the artwork as necessary for the duration of the project and/or the artwork.



## Utility Box Art Wrap Program

### Policies and Guidelines

---

- Coordinate inter-agency permitting and agreements related to installation, maintenance and removal/replacement of vinyl art wraps.
- The City has the discretion to select or reject any artwork.
- The City reserves the right to remove the artwork at any time.

#### **Design Criteria and Guidelines:**

- All artwork must be an original created by the artist.
- Art should be bright, bold, and inviting. Dark colors should be used sparingly due to the potential of overheating utility boxes. Artwork that contains majority of dark colors may not be considered.
- Art should be visible from a distance.
- Artwork must not contain:
  - Political statements or specific persons
  - Discriminatory imagery or language
  - References, symbols, or numerology specific to any religion
  - Copyrighted or trademarked material
  - Corporate or organizational branding (with the possible exception of Fridley-based non-profit organizations)
  - Images of illegal activity
  - Content that is defamatory, violates applicable law, or is deemed offensive or controversial by the selection committee
  - Representation of traffic signals, signs, colors, or other imagery that may distract or confuse pedestrians or motorists
  - Attachments of objects other than the printed vinyl wrap to the utility box

#### **Selection Criteria**

Selection scoring shall be completed by the Public Arts Commission using a 100-point scale:

- Submitted artwork meets criteria **(yes/no)**
- Artist is a Fridley resident or is representing a Fridley-based non-profit organization, or provides a narrative detailing a strong connection to the City of Fridley **(up to 30 points)**
- Artwork is original and visually appealing to the evaluator **(up to 30 points)**
- Artwork is bold and inviting and will be visually impactful if applied to a utility box at the locations specified in the pilot program **(up to 20 points)**
- Subject of artwork celebrates Fridley and/or contains design elements identifiable to the evaluator as being unique to Fridley **(up to 20 points)**

Total: \_\_\_\_\_ / 100 possible points



# Utility Box Art Wrap Program

Policies  
and Guidelines

---

## Program Resources:

Staff contacts for the Utility Box Art Wrap Pilot Program are:

**Mike Maher**

Parks and Recreation Director  
(763)572-3575

[Mike.Maher@FridleyMN.Gov](mailto:Mike.Maher@FridleyMN.Gov)

**Jesslyn Quiram**

Engineering Technician  
(763)572-3546

[Jesslyn.Quiram@FridleyMN.Gov](mailto:Jesslyn.Quiram@FridleyMN.Gov)



# Utility Box Art Wrap Program

## Policies and Guidelines

### Design Specifications and Template:

PUBLIC ARTS COMMISSION  
UTILITY BOX WRAP PILOT PROGRAM

Figure #1: Utility Box Template  
November 2025

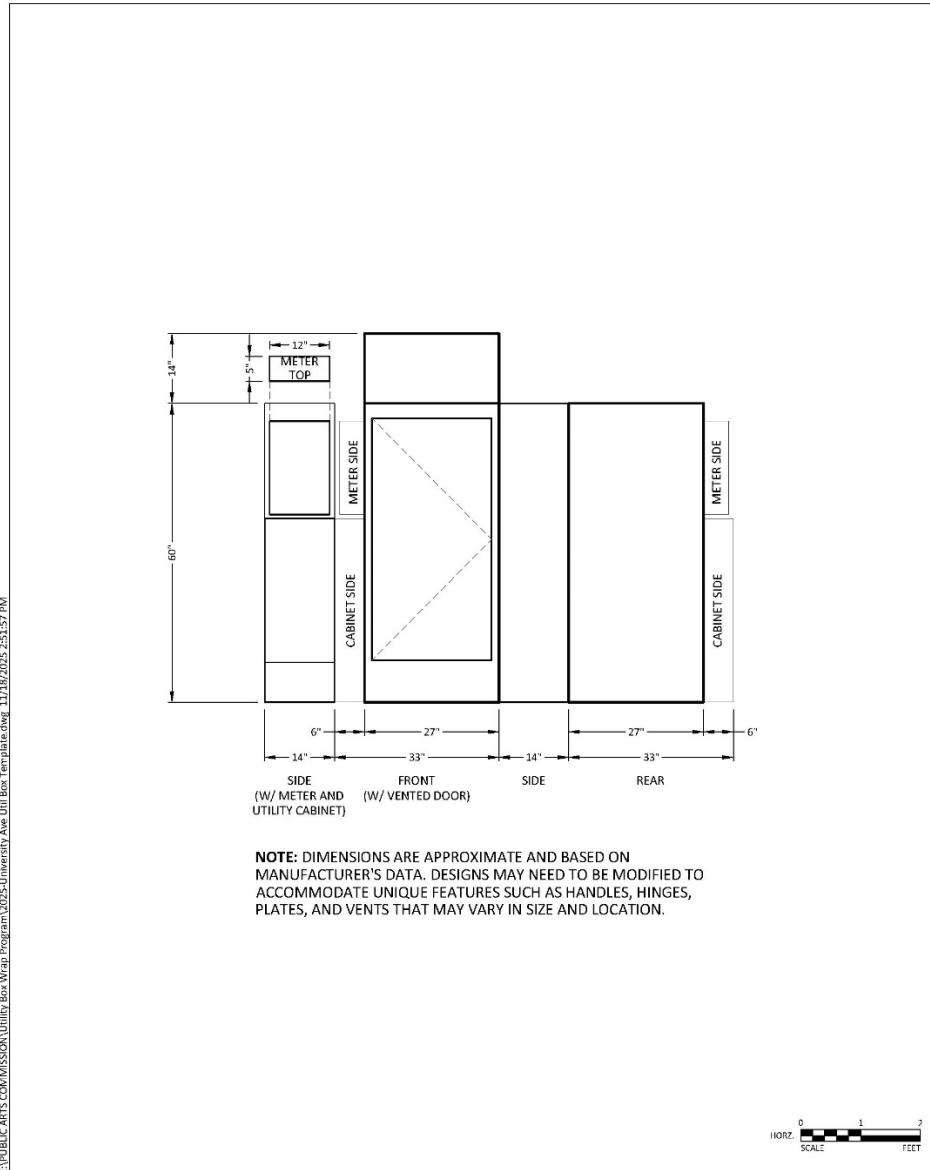

### Utility Box Locations:



# Utility Box Art Wrap Program

Policies and Guidelines



UTILITY BOX LOCATIONS  
1 OF 4

UNIVERSITY LIGHTING PROJECT  
JULY 23, 2025







# Utility Box Art Wrap Program

Policies and Guidelines



UTILITY BOX LOCATIONS  
3 OF 4

UNIVERSITY LIGHTING PROJECT  
JULY 23, 2025

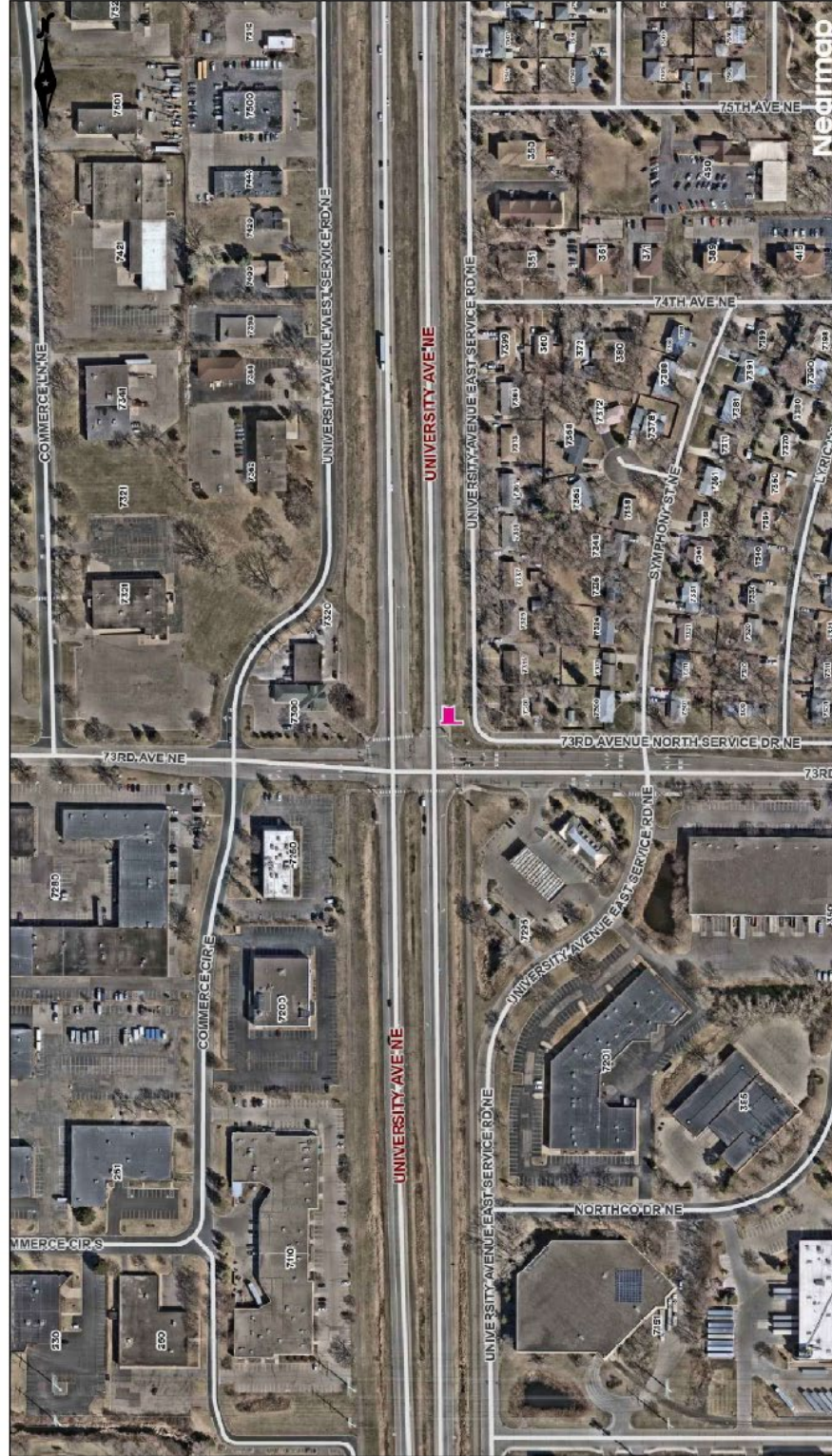



# Utility Box Art Wrap Program

## Policies and Guidelines



UTILITY BOX LOCATIONS  
4 OF 4

UNIVERSITY LIGHTING PROJECT  
JULY 23, 2025

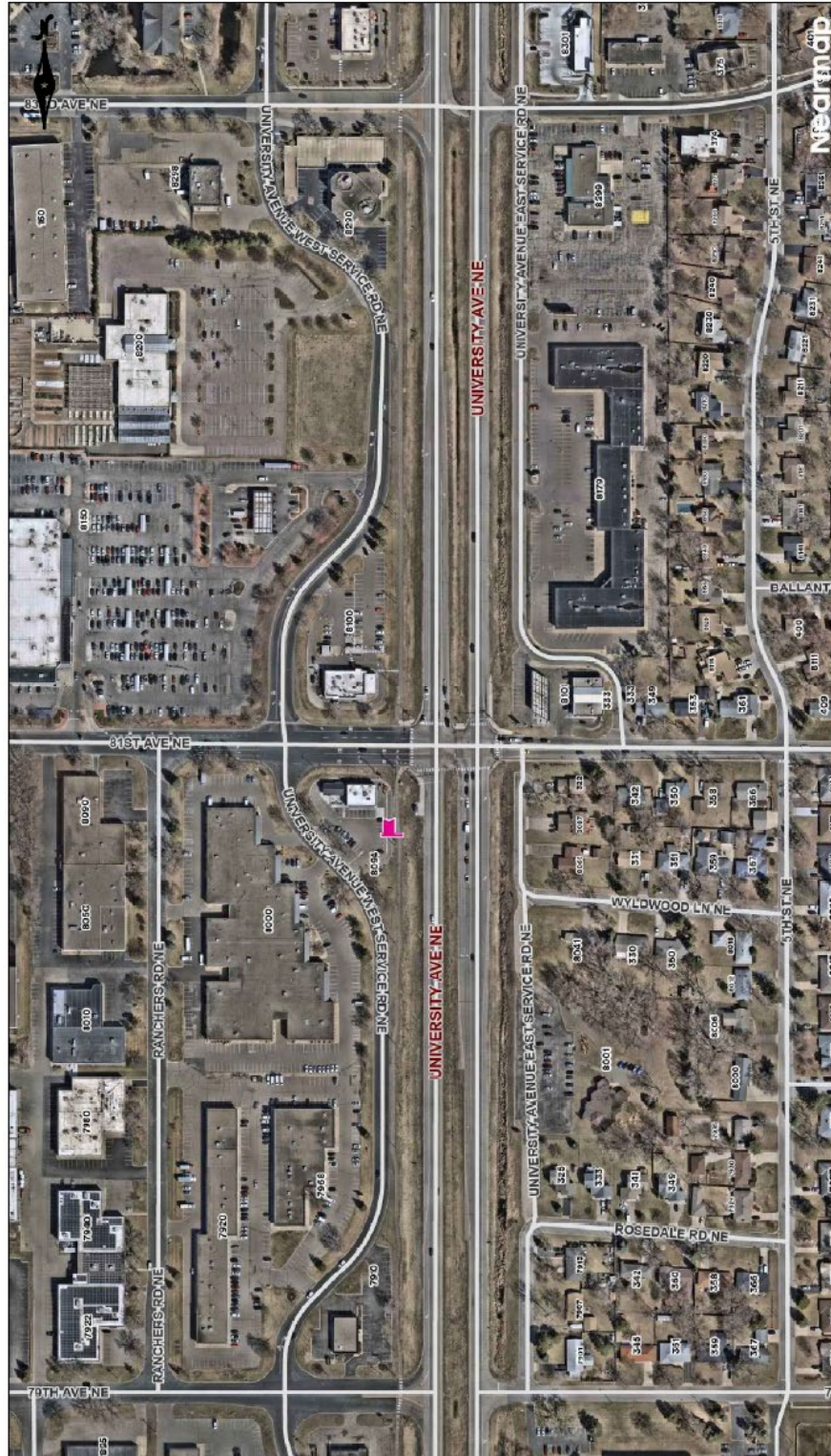



# Utility Box Wrap Program - Artist Application



## Artist Information:

Name \_\_\_\_\_

Address \_\_\_\_\_

\_\_\_\_\_

Phone \_\_\_\_\_

Email \_\_\_\_\_

Is Artist:

Youth (< 18 Years Old)

Adult (18+)

## If youth is selected provide legal guardian information:

Name \_\_\_\_\_

Relationship to the Artist \_\_\_\_\_

Address \_\_\_\_\_

\_\_\_\_\_

Phone \_\_\_\_\_

Email \_\_\_\_\_

Provide a narrative describing the artist's connection to the City of Fridley (100 words or less).

# Utility Box Wrap Program - Artist Application



Provide a description of the artwork including title. If artwork contains elements specific to a specific ethnic or cultural group, include narrative of artist's background or collaboration demonstrating cultural representation.